

# NEPTUNE PLUS

## RESIDENTIAL FLUIDROWER

The compact FDF Neptune Plus FluidRower is FDF's entry-level residential machine with all the features for any home workout program.

The Neptune Plus has 4 levels of Adjustable Fluid Resistance. At level 1, the Fluid Resistance is suitable for beginners, rehabilitation patients or deconditioned participants just starting on their fitness journey. Dial to level 4 for high-intensity for athletes, interval training (HIIT) or short sprints.

The aluminium seat rail and a sculpted steel frame wraps around the adjustable Fluid Resistance system, making it a very robust machine.

The Neptune Plus offers silky smooth resistance at any speed and any level, with a firm instant catch and a consistent resistance through the entire stroke. Pivoting footplates improve the ergonomics for less flexible or deconditioned users, and a shaped and textured seat ensure a smooth slide with every stroke.

The transport wheels make it easy to move and it is designed to be stored vertical, creating a minimal footprint when not in use.



# FLUID ROWER



**STEEL ALUMINIUM FRAME**

Industrial nylon belt for smooth and quiet rowing

Sculpted steel frame

Multi-level monitor

Textured seat to prevent slipping

Height adjustable footplate

Transport wheels

Smooth, silent seat action

Ergonomic contoured handle

Aluminium seat rail

Double sealed precision aligned twin fluid resistance tank

Elevated legs

View the full range of rowers at [FLUIDROWER.COM](https://www.fluidrower.com)

Visit [FIRSTDEGREEFITNESS.COM](https://www.firstdegreefitness.com) to view all FDF products ranges.

# NEPTUNE PLUS FLUIDROWER

## PRODUCT SPECIFICATIONS

PRODUCT MODEL NO:	NEPP
FLUID RESISTANCE:	FDF Horizontal Plus Twin Tank - 4 Levels
MONITOR:	FDF Multi-Level Rower Console
PRODUCT NET WEIGHT:	27.6kg [60.85lb]
PRODUCT GROSS WEIGHT:	34.0kg [74.96]
DIMENSIONS:	L 1,990mm [78.35"] x W 520mm [20.47"] x H 520mm [20.47"]
MIN ACTIVE AREA REQUIRED:	L 2,310mm [90.94"] x W 1,150mm [45.27"]
STORED VERTICAL DIMENSIONS:	L 520mm [20.47"] x W 520mm [20.475"] x H 1,990mm [78.35"]
MAX USER WEIGHT:	150kg [330lb]
COMMERCIAL WARRANTY:	Frame 10 years - Fluid Tank 5 years Mechanical and all other non wearing components - 2 years



## CONSOLE FEATURES

- + Mode - Access to various settings
- + Time - Elapsed time
- + Total Count - Range from 0-9999
- + Calories burned
- + Tempo - 0 to 180 beeps per minute
- + SPM - Strokes per minute

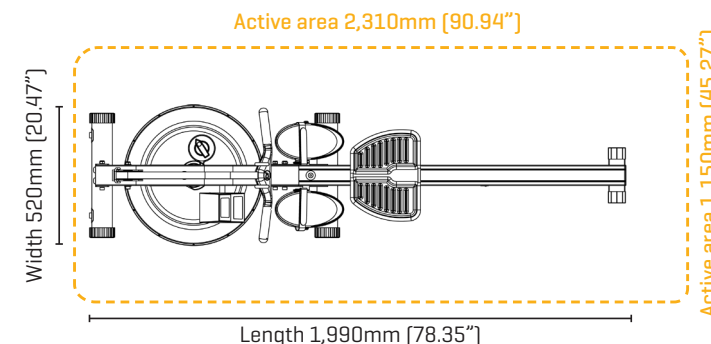

## ABOUT FDF (FIRST DEGREE FITNESS)

FDF is the leader in designing and manufacturing a range of adjustable Fluid Resistance fitness machines for commercial and residential applications. At the heart of the fitness range is our unique and patented Twin Tank Fluid Resistance system. The adjustable Fluid Resistance system challenged the conventional thinking of how water could work to provide adjustable resistance rather than just dead weight for a flywheel effect. The patented Twin Tank system provides silky smooth resistance at any speed and is perfect for cardio training, warm-ups, cool downs, intense HIIT workouts or rehabilitation programs. FDF categorizes the range of adjustable Fluid Resistance machines under the banners, FluidRower, FluidExercise and FluidPowerZone, see the adjacent web links. FDF products are distributed throughout the globe and are popular in Fitness Centers, Hotels and Apartments, Sporting Clubs, Universities, First Responders, Defence Force Training Facilities and Physical Rehabilitation Clinics.

\* FDF reserves the right to modify any product design, manufacture or aesthetic without notice or consultation. Product specifications and warranties may vary from country to country.



View all FDF products ranges at

[FLUIDROWER.com](https://www.fluidrower.com)

[FLUIDEXERCISE.com](https://www.fluidexercise.com)

[FLUIDPOWERZONE.com](https://www.fluidpowerzone.com)