

# NEON PLUS BLACK

## RESIDENTIAL FLUIDROWER

The FDF NEON Plus FluidRower has a robust sculpted steel frame that wraps around the twin tank that makes a stable rowing platform as well as a luxurious modern style.

The resistance is provided by our patented Twin Tank 4 level Adjustable Fluid Resistance system. The 4 levels for Fluid Resistance is manually adjusted by turning a tactile and audible selector dial, assuring accurate and even level selection. The 4 resistance levels provide a consistent resistance throughout the entire rowing stroke, the range of adjustability from level 1 “feather light” to level 4 for an intense workout.

Easy to stow-away, stand this model on its end for compact storage.

The Neon Plus is also compatible with FDF’s optional Seat Back Kit for extra lumbar support.

To illuminate your home gym, the NEON FluidRower series is available in bright green, yellow and orange coloured frame options.

### NEON SERIES AVAILABLE IN



# FLUID ROWER



MINIMUM

MAXIMUM

STEEL  
FRAME

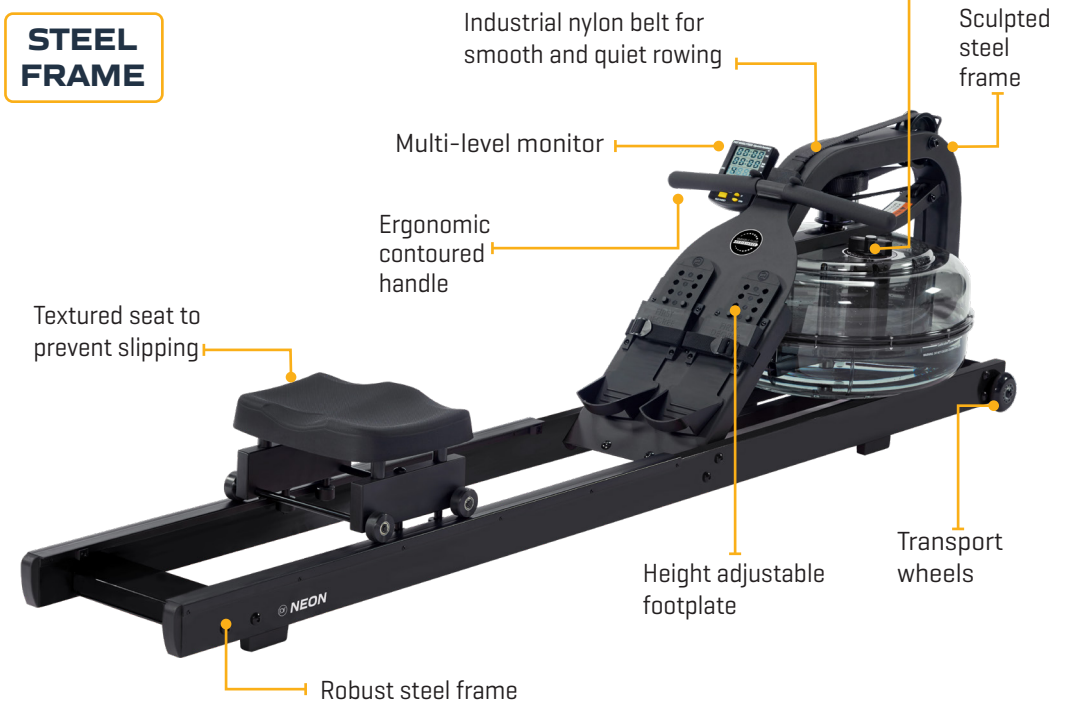

View the full range of rowers at [FLUIDROWER.COM](https://www.fluidrower.com)

Visit [FIRSTDEGREEFITNESS.COM](https://www.firstdegreefitness.com) to view all FDF product ranges.

# NEON PLUS BLACK FLUIDROWER

## PRODUCT SPECIFICATIONS

PRODUCT MODEL NO:	EOBP
FLUID RESISTANCE:	Horizontal FDF Twin Tank - 4 Levels
MONITOR:	FDF PLUS Colsole
PRODUCT NET WEIGHT:	35.16kg [77.51lb]
PRODUCT GROSS WEIGHT:	39.14kg [86.28lb]
DIMENSIONS:	L 2,130mm [83.85"] x W 540mm [21.25"] x H 520mm [20.47"]
MIN ACTIVE AREA REQUIRED:	L 2,450mm [9645"] x W 1,150mm [45.27"]
STORED VERTICAL DIMENSIONS:	L 520mm [20.47"] x W 540mm [21.25"] x H 2,130mm [83.85"]
MAX USER WEIGHT:	150kg [330lb]
COMMERCIAL WARRANTY:	Frame 10 years - Fluid Tank 5 years Mechanical and all other non wearing components - 2 years

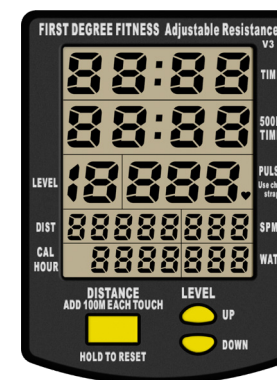

## CONSOLE FEATURES

- + Auto start
- + Time - Elapsed time
- + 500M Time - Time to row 500 meters
- + Watt - Unit of power per stroke
- + Distance - Updated every meter
- + SPM - Strokes per minute
- + Calories burned per hour
- + Level - Up/Down to align level of selected fluid resistance
- + Pulse - Requires optional fitted receiver and chest strap (sold separately)

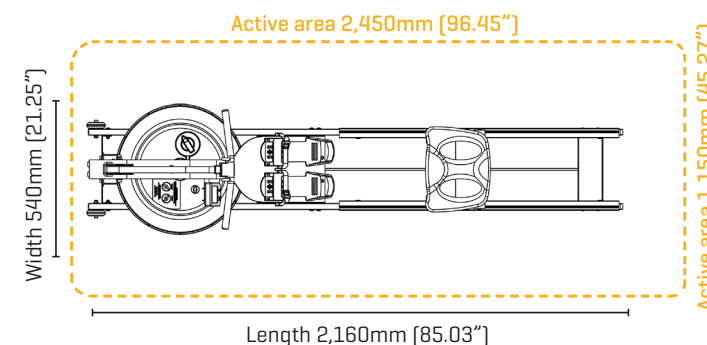

## ABOUT FDF (FIRST DEGREE FITNESS)

FDF is the leader in designing and manufacturing a range of adjustable Fluid Resistance fitness machines for commercial and residential applications. At the heart of the fitness range is our unique and patented Twin Tank Fluid Resistance system. The adjustable Fluid Resistance system challenged the conventional thinking of how water could work to provide adjustable resistance rather than just a liquid mass flywheel. The patented Twin Tank system provides silky smooth resistance at any speed and is perfect for cardio training, warm-ups, cool downs, intense HIIT workouts or rehabilitation programs. FDF categorizes the range of adjustable Fluid Resistance machines under the banners, **FluidRower**, **FluidExercise** and **FluidPowerZone**, see the adjacent web links. FDF products are distributed throughout the globe and are popular in Fitness Centers, Hotels and Apartments, Sporting Clubs, Universities, First Responders, Defence Force Training Facilities and Physical Rehabilitation Clinics.



## OPTIONAL FLUIDROWER ACCESSORY



SEAT BACK KIT

View all products ranges at

[FLUIDPOWERZONE.com](https://www.fluidpowerzone.com)

[FLUIDROWER.com](https://www.fluidrower.com)

[FLUIDEXERCISE.com](https://www.fluidexercise.com)