

APOLLO V LIGHT OAK

RESIDENTIAL FLUIDROWER

The FDF Apollo V FluidRower is one of our highest sought after machine for its performance and beautiful construction from ethically sourced American Ash wood in a light oak stain. The wood frame wraps around a robust sculpted steel frame, ensuring product integrity as well as a luxurious modern style.

The Apollo V has 5 levels of adjustable Fluid Resistance provided by our patented Twin Tank system. At level 1, the Fluid Resistance is suitable for beginners, deconditioned participants or rehabilitation patients just starting on their fitness journey. Dial to level 5 for high-intensity interval training (HIIT) or short sprints.

The Apollo V offers silky smooth resistance at any speed and at any level. With a firm instant catch and a consistent resistance through the entire stroke, it provides the closest emulation of on-water rowing, encouraging you at every stroke to do a little more.

The Apollo V boasts a compact footprint and can be stored on its end with ease. It is appealing to a broad market, including rehab and seniors. The Apollo V is also compatible with FDF's optional Seat Back Kit for extra lumbar support

FLUID ROWER



MINIMUM



MAXIMUM

**HYBRID
WOOD/STEEL
FRAME**

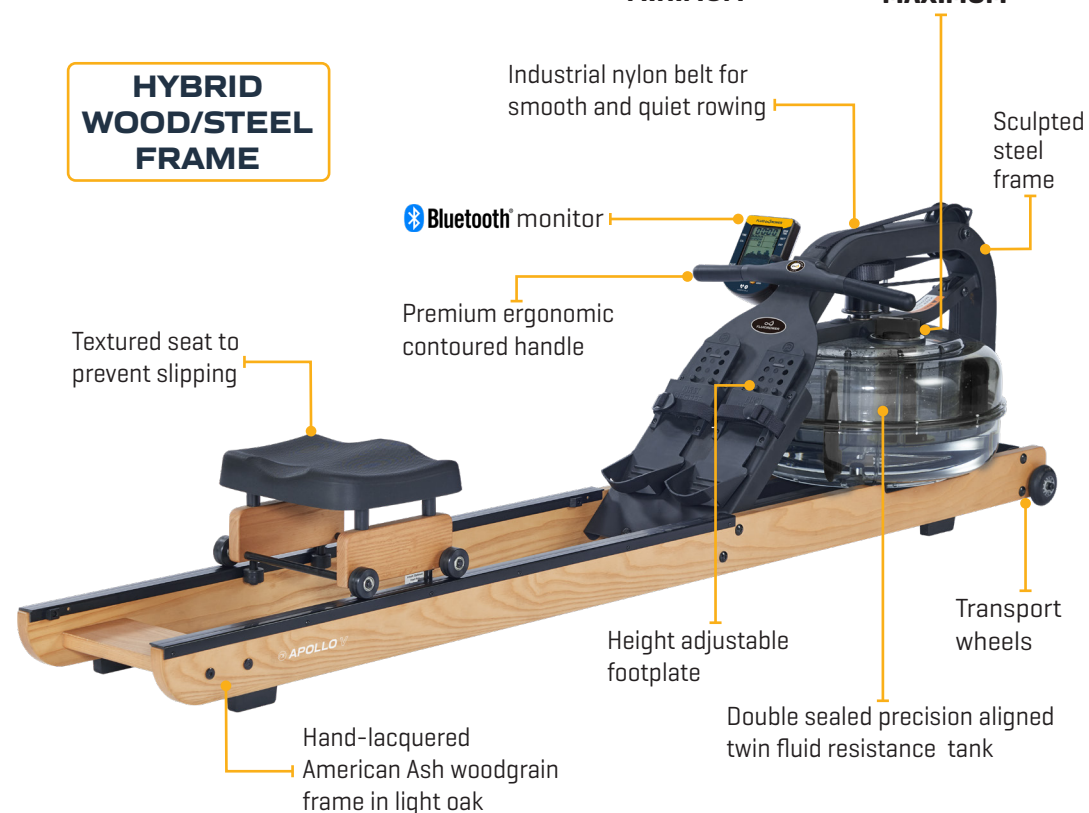

View the full range of rowers at [FLUIDROWER.COM](https://www.fluidrower.com)

Visit [FIRSTDEGREEFITNESS.COM](https://www.firstdegreefitness.com) to view all FDF product ranges.

APOLLO V FLUIDROWER

PRODUCT SPECIFICATIONS

PRODUCT MODEL NO:	APVV
FLUID RESISTANCE:	FDF Horizontal V Twin Tank - 5 Levels
MONITOR:	FDF Bluetooth / Heart Rate Compatible
PRODUCT NET WEIGHT:	32.70kg [72.09lb]
PRODUCT GROSS WEIGHT:	39.50kg [87.08lb]
DIMENSIONS:	L 2,130mm [83.85"] x W 540mm [21.25"] x H 520mm [20.47"]
MIN ACTIVE AREA REQUIRED:	L 2,450mm [96.45"] x W 1,150mm [45.27"]
STORED VERTICAL DIMENSIONS:	L 520mm [20.47"] x W 540mm [21.25"] x H 2,130mm [83.85"]
MAX USER WEIGHT:	150kg [330lb]
COMMERCIAL WARRANTY:	Frame 10 years - Fluid Tank 5 years Mechanical and all other non wearing components - 2 years



CONSOLE FEATURES

- + Bluetooth Connectivity
- + Auto start
- + Time - Elapsed time
- + Level - Auto to selected resistance level
- + 500M Time - Time to row 500 meters
- + Watt - Unit of power per stroke
- + Distance - Updated every second
- + SPM - Strokes per minute
- + Power Graphs - 2 Options
- + Heart rate - Polar compatible
- + Calories burned per hour

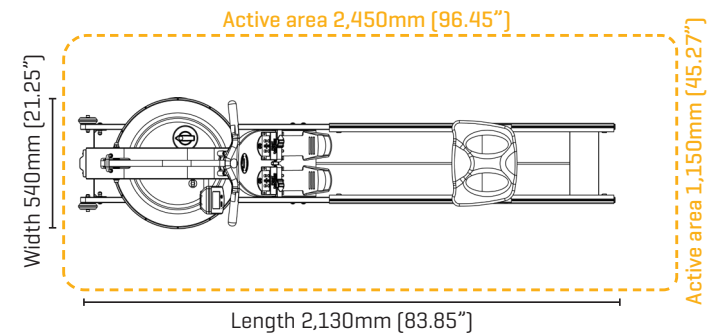

ABOUT FDF (FIRST DEGREE FITNESS)

FDF is the leader in designing and manufacturing a range of adjustable Fluid Resistance fitness machines for commercial and residential applications. At the heart of the fitness range is our unique and patented Twin Tank Fluid Resistance system. The adjustable Fluid Resistance system challenged the conventional thinking of how water could work to provide adjustable resistance rather than just a liquid mass flywheel. The patented Twin Tank system provides silky smooth resistance at any speed and is perfect for cardio training, warm-ups, cool downs, intense HIIT workouts or rehabilitation programs. FDF categorizes the range of adjustable Fluid Resistance machines under the banners, **FluidRower**, **FluidExercise** and **FluidPowerZone**, see the adjacent web links. FDF products are distributed throughout the globe and are popular in Fitness Centers, Hotels and Apartments, Sporting Clubs, Universities, First Responders, Defence Force Training Facilities and Physical Rehabilitation Clinics.

OPTIONAL FLUIDROWER ACCESSORIES



TOUCH HEART RATE HANDLE



SMARTPHONE HOLDER



SEAT BACK KIT



View all product ranges at

FLUIDPOWERZONE.com

FLUIDROWER.com

FLUIDEXERCISE.com

* FDF reserves the right to modify any product design, manufacture or aesthetic without notice or consultation. Product specifications and warranties may vary from country to country.