

MEDICAL UBE E950

UPPER BODY ERGOMETER MEDICAL & REHABILITATION MODEL

The FluidExercise E950 Medical Upper Body Ergometer with removable seat and wheelchair ramp, incorporates multiple adjustments to accommodate any and all athletes, fitness enthusiasts or patients on a rehabilitation program. The E950 is a high-quality commercial grade machine that offers maximum operational versatility, bidirectional seated or standing upper body cycling.

Resistance can be adjusted on the E950 via our patented 10 x Adjustable Fluid Resistance Twin Tank. The resistance is silky smooth at any RPM so you can choose a pace that works for you completely independent of the resistance set. The adjustable Fluid Resistance can be changed quickly and easily from 'feather-light' to Olympic challenge and operates in both the forward and reverse direction for total muscle engagement. You can even change resistance on the fly.

The E950 seat can be removed entirely for wheelchair access, or for fitness ball and standing access. The base platform is designed to accommodate all forms of wheelchairs (standard and sports specific). With the ability to adjust the seat position, the crank height, the length of the crank, and the angle of the hand grip, the ergonomics can be ideally tailored to many individual requirements.

Medically approved, the E950 Medical Upper Body Ergometer is the ideal inclusion for a wide variety of training and rehabilitation applications. The E950 has the advantage that it does not require an external power supply so can be installed on any flat surface.



SEATED



STANDING

FLUID EXERCISE



View the full range of Upper Body Ergometers at [FLUIDEXERCISE.COM](https://www.fluidexercise.com)

Visit [FIRSTDEGREEFITNESS.COM](https://www.firstdegreefitness.com) to view all FDF product ranges.

MEDICAL UBE E950 FLUIDEXERCISE

PRODUCT SPECIFICATIONS

PRODUCT MODEL NO:	E950
FLUID RESISTANCE:	Vertical FDF Twin Tank - 10 levels
MONITOR:	FDF Bluetooth / Heart Rate Compatible
PRODUCT NET WEIGHT:	133.43kg [293.90lb]
PRODUCT GROSS WEIGHT:	155.7kg [343.19lb]
DIMENSIONS:	L 1810mm [71.26"] x W 1020mm [40.16"] x H 1480mm [58.27"]
MIN ACTIVE AREA REQUIRED:	L 2410mm [94.88"] x W 1370mm [53.93"]
MAX USER WEIGHT:	150kg [330lb]
ARM CRANK HEIGHT:	Height adjustable from 715mm to 1245mm [28.14" to 49.05"]
ARM CRANK LENGTH:	Length adjustable from 120mm to 240mm [4.72" to 9.44"]
LOW SEAT HEIGHT:	540mm [21.3"]
COMMERCIAL WARRANTY:	Frame 10 years - Fluid Tank 5 years Mechanical and all other non wearing components - 2 years



CONSOLE FEATURES

- + Bluetooth Connectivity
- + Auto start
- + Time - Elapsed time
- + Level - Auto to selected resistance level
- + Watt - Unit of power
- + RPM - Revolutions per minute
- + Power Graphs - 2 Options
- + Heart rate - Polar compatible
- + Calories burned per hour



SEAT REMOVED FOR WHEELCHAIR ACCESS

ADJUSTABLE CRANK ARM LENGTH & HAND GRIPS



ADJUSTABLE CRANK HEIGHT - RANGE 530mm (20.83")

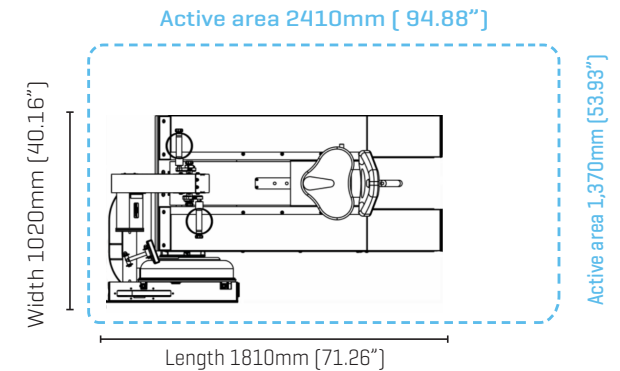

ABOUT FDF (FIRST DEGREE FITNESS)

FDF is the leader in designing and manufacturing a range of adjustable Fluid Resistance fitness machines for commercial and residential applications. At the heart of the fitness range is our unique and patented Twin Tank Fluid Resistance system. The adjustable Fluid Resistance system challenged the conventional thinking of how water could work to provide adjustable resistance rather than just a liquid mass flywheel. The patented Twin Tank system provides silky smooth resistance at any speed and is perfect for cardio training, warm-ups, cool downs, intense HIIT workouts or rehabilitation programs. FDF categorizes the range of adjustable Fluid Resistance machines under the banners, **FluidRower**, **FluidExercise** and **FluidPowerZone**, see the adjacent web links. FDF products are distributed throughout the globe and are popular in Fitness Centers, Hotels and Apartments, Sporting Clubs, Universities, First Responders, Defence Force Training Facilities and Physical Rehabilitation Clinics.

* FDF reserves the right to modify any product design, manufacture or aesthetic without notice or consultation. Product specifications and warranties may vary from country to country.



View all product ranges at
FLUIDROWER.com

FLUIDEXERCISE.com
FLUIDPOWERZONE.com

FLUIDROWER



FLUIDPOWERZONE



FLUIDEXERCISE

